

Lightning / Surge Protection for RadioRA® 2, HomeWorks® QS, and HomeWorks® Devices

Table of Contents

Overview	2
Recommendations	3
Surge Protection Equipment	4
Breaker Panel Protection	4
RS-232 Protection.....	4
RS-485 Protection.....	5
H48/D48 Interface Protection (HomeWorks® QS and HomeWorks® only)	5
Line Voltage Protection	6
Breaker Panel Equipment Placement.....	6
Breaker Panel Wiring Detail	6
Dimming Module Equipment Placement	7
Dimming Module Wiring Detail.....	7
RadioRA® 2	8
RS-232 Equipment Placement	8, 9
RS-232 Component Wiring Detail.....	8, 9
RS-485 Equipment Placement	10, 11
RS-485 Component Wiring Detail.....	10, 11
HomeWorks® QS	12
RS-485 Equipment Placement.	12, 14
RS-485 Component Wiring Detail.....	13, 15
HomeWorks®	16
RS-232 Equipment Placement.	16, 17
RS-232 Component Wiring Detail.....	16, 17
RS-485 Equipment Placement	18, 20
RS-485 Component Wiring Detail.....	19, 20
H48/D48 Equipment Placement	21, 23
H48/D48 Component Wiring Detail.....	22, 24
Combination RS-485 and H48/D48 Component Wiring Detail.....	24
Lightning Strike Information	25
Contact Information	26

Overview

Lightning strikes may cause permanent damage to household electrical equipment, including Lutron® System components. Lightning strike-damaged equipment is not covered by the Lutron® Warranty and should be reported to the homeowner's insurance company.

All Lutron® products are designed with integrated surge suppression devices. (Lutron follows the IEEE C62.41-1991 recommended practice on Surge Voltages in Low Voltage AC Power Circuits.) These integrated suppression devices are effective for preventing damage in most installations. Despite this fact, high-risk homes that are located in lightning-prone locations may experience surge levels that are capable of damaging Lutron® devices, particularly in the case of a direct lightning strike on the property. (For additional information on lightning-prone areas of the U.S. and abroad, see the maps at the end of this application note.) Although this type of damage is typically covered by the homeowner's insurance, there is inconvenience involved in getting equipment replaced and/or having non-functional products. Many installers and homeowners are interested in adding additional protection hardware to their systems to minimize the risk of this sort of disruption. This application note was written to address these interests.

The devices recommended in this document are some of the most rugged and cost-effective protection devices available. Although installing these devices will provide an added degree of protection, in the most extreme circumstances damage is still a possibility. The likelihood of damage occurring will be greatly reduced when surge protection is used. This application note covers surge protection of low voltage links and the high voltage side of the installation with use of AC panel mount surge suppression with filtering. This may require additional solutions including: lightning rods, grounding methods, and local (near to a component) surge suppression, etc. High voltage surge suppression requires expertise (consider consultants if this is not internal to your organization) and up-front planning/design.

Our customers often ask why Lutron doesn't integrate the surge protection provided by the external devices directly into our products. The primary reason is that over time (many surges) or given a surge with sufficient energy the suppression devices can/will fail. When they fail they tend to fail "shorted" to ground. This failure mode is "good" in the respect that it continues to protect the Lutron® equipment, although communications on the link will no longer work. External surge protection devices can be replaced easily, at low cost, with no reprogramming. If the devices were built into the Lutron® product, the entire product would have to be replaced. We may have delayed the product replacement but we haven't prevented it.

Other benefits of external protection are:

- For maximum protection, it is best to have surge energy shunted away before it gets into the Lutron® equipment
- The physical space required is impractical to implement in many products
- Not every customer needs to "pay" (in terms of size or cost) for this protection (for example, per the lightning strike maps, someone in the Northwest with a single building install, no integration connected,...)

Recommendations

Installation Based Recommendations

- Protect all electrical breaker panels feeding dimmers, processors, and dimming panels. A panel mounted surge suppression unit with enhanced filtering will protect equipment from catastrophic events, clean the power, and suppress internally generated transients that can lockup electronics, necessitate reprogramming of controls, and gradually deteriorate sensitive electronics. See Section 3.4.3, IEEE Std.1100-2005.
- Protect all RS-232 ports with permanently connected third party equipment (typically other processors that are part of integration systems). While RS-232 communication wire runs are themselves short, all of the equipment and wire runs that are connected to the third-party equipment provide an electrical path to conduct damaging surges. Damage most often occurs because the ground referencing between the two systems can become separated during a surge. This creates high voltages that damage the RS-232 ports, and is the most common type of port failure.
- Protect any link or bus that travels between buildings regardless of geographical location. Again damage may occur because the ground referencing between buildings can become separated during a lightning strike. Lutron recommends using fiber optic communication between buildings. Using fiber cable breaks the electrical connection (by using light rather than current carrying conductors) and will minimize damage if one building gets struck. Refer to “**RS-485 Communication Using Fiber Optics Modem FAQ**” on the HomeWorks® Resource Website.
- Protect Links/Busses that have wire runs over 500 ft (152.4 m) long even if they are contained within a single building. A long wire run is susceptible to high levels of capacitively coupled surge energy as it travels alongside other wires and through the structure and mechanicals of the building.

Geographical Based Recommendations

Refer to the lightning strike maps at the end of this document.

- Protect all breaker panels feeding lighting system from internal and external surges.
- Protect 120 V~ outputs from dimming modules which go outside (such as to landscape lighting) in areas that are determined to be at high risk, such as those at high elevations, and those in close proximity to water.
- Protect **all** links/busses for installations in **orange** and **red** areas. In the US, for example, this would include Florida, the Southeast, and portions of the Midwest.
- Protect **all** links/busses for installations in areas that are determined to be at high risk, such as those at high elevations, and those in close proximity to water.

Note: The lightning strike maps in this application note are best viewed in color. Please view on a computer or print out in color.

Surge Protection Equipment

The following surge protection equipment may be used to protect lighting panels and all dimming controls. The following suppression units will protect the electrical system from external transients entering the system through the power lines. The filtering part of the units will clean the power, and suppress internally generated transients that can lockup electronics, necessitate reprogramming of controls, and gradually deteriorate sensitive electronics. See Section 3.4.3, IEEE Std.1100-2005.

Breaker Panel Protection

1. Total Protection Solutions Breaker Panel Protection

Manufacturer: Total Protection Solutions, LLC.
Model Number: TK-TTLP-1S240-FL
Website: www.TPSsurge.com

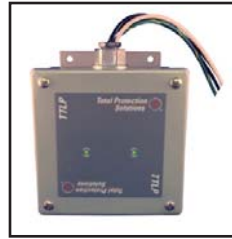

Photograph courtesy of
Total Protection Solutions

RS-232 Surge Protection

The following surge protection equipment may be used to protect RS-232 ports

1. Total Protection Solutions RS-232 Surge Protection

Manufacturer: Total Protection Solutions, LLC
Model Number: TK-CT2-DB9-DIN2
Website: www.TPSsurge.com



Photograph courtesy of
Total Protection Solutions

Surge Protection Equipment *(continued)*

RS-485 Protection

The surge protection equipment listed below may be used to protect the RS-485 links.

1. Total Protection Solutions RS-485 Surge Protection

Manufacturer: Total Protection Solutions, LLC.
 Model Number: TK-CT2-24LIT24
 Model Number: TK-CT2-24LIT12
 Model Number: TK-CT2-24LIT4
 Website: www.TPSsurge.com



Photograph courtesy of Total Protection Solutions

TK-CT2-24LIT24 (12 pair) TK-CT2-24LIT12 (6 pair) TK-CT2-24LIT4 (2 pair)

Note: 24-Terminal (12-pair), 12-terminal (6-pair), and 4-terminal (2-pair) devices are available. Choose model based on the number of RS-485 links and H48/D48 dimming busses to be protected. Same unit can be used for both dimming busses and links.

H48/D48 dimming interface Protection (HomeWorks® and HomeWorks® QS only)

The surge protection equipment listed below may be used to protect the H48/D48 dimming interface.

1. Total Protection Solutions H48/D48 Surge Protection

Manufacturer: Total Protection Solutions, LLC.
 Model Number: TK-CT2-24LIT24
 Model Number: TK-CT2-24LIT12



Photograph courtesy of Total Protection Solutions

TK-CT2-24LIT24 (12 pair) TK-CT2-24LIT12 (6 pair)

Website: www.TPSsurge.com

Note: 24-Terminal (12-pair) and 12-terminal (6-pair) devices are available. Choose model based on the number of RS-485 links and H48/D48 dimming busses to be protected. Same unit can be used for both dimming busses and links.

Line Voltage Protection

Breaker Panel Equipment Placement – Using Total Protection Solutions

Example: Connection to breaker panel.

Locate and install one TK-TTLP-1S240-FL at each breaker panel feeding Homeworks® processors, dimming modules and remote module interface.

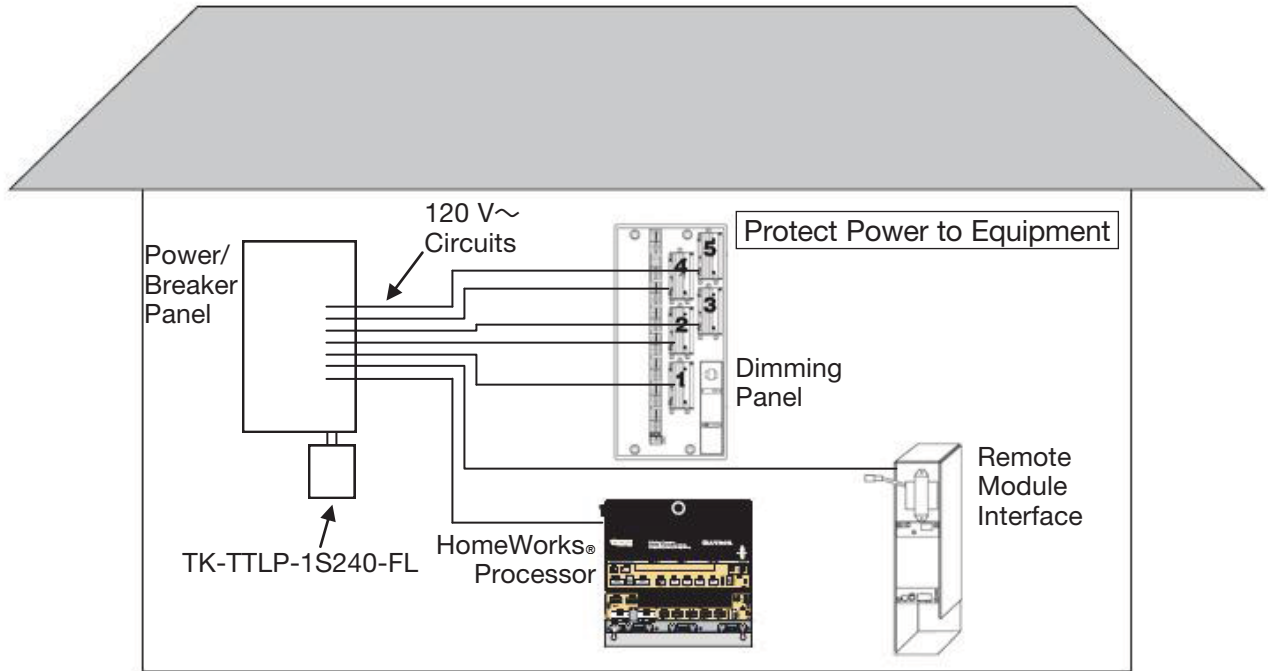

Breaker Panel Wiring Detail – Using Total Protection Solutions

Installation Based Recommendations

Install on all breaker panels powering Lutron® equipment.

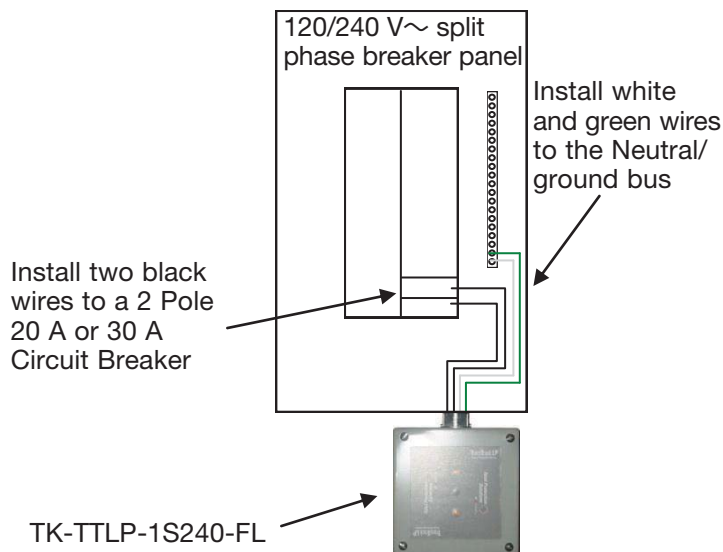

Line Voltage Protection *(continued)*

Dimming Module Equipment Placement – Using Total Protection Solutions

Example: Connection to 120 V~ landscape lighting

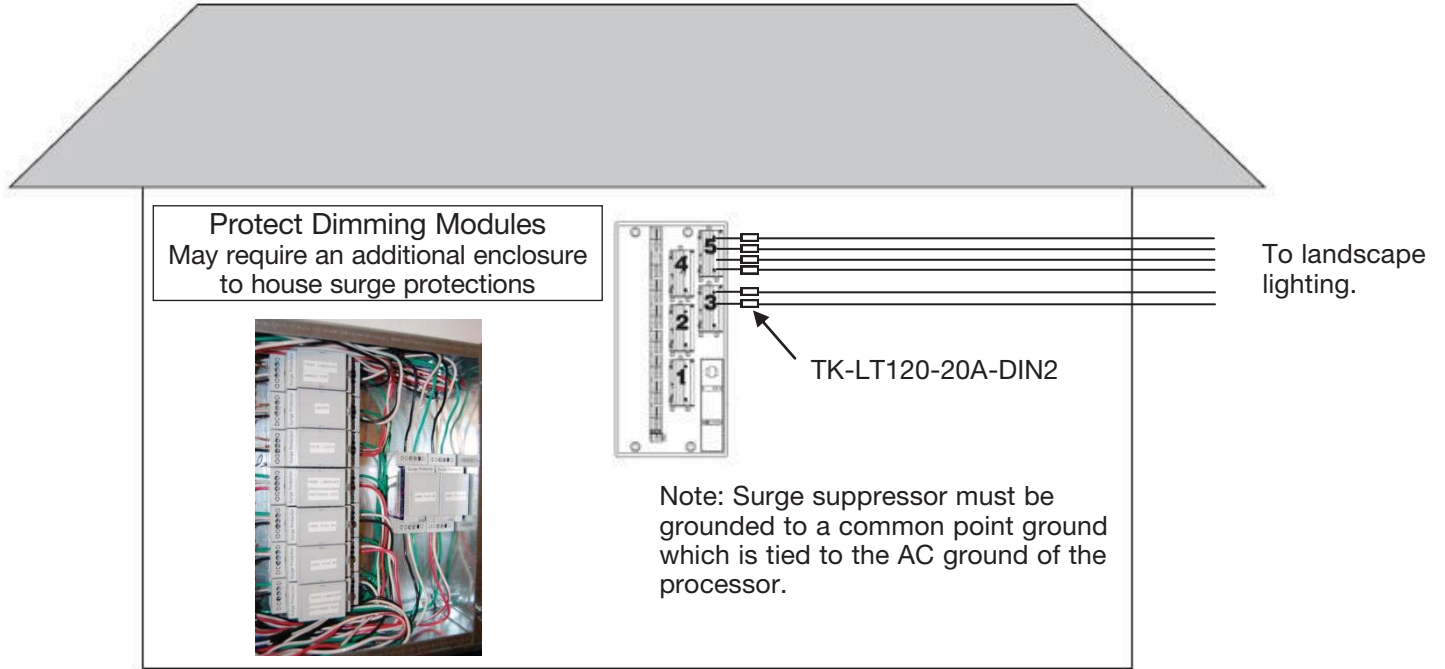

Dimming Module Wiring Detail – Using Total Protection Solutions

Total Protection Solutions Installation Based Recommendations



RadioRA® 2

RS-232 Equipment Placement – Using Total Protection Solutions

Example: Total Protection Solutions Model # TK-CT2-DB9-DIN2 Connection to Third Party RS-232 Equipment

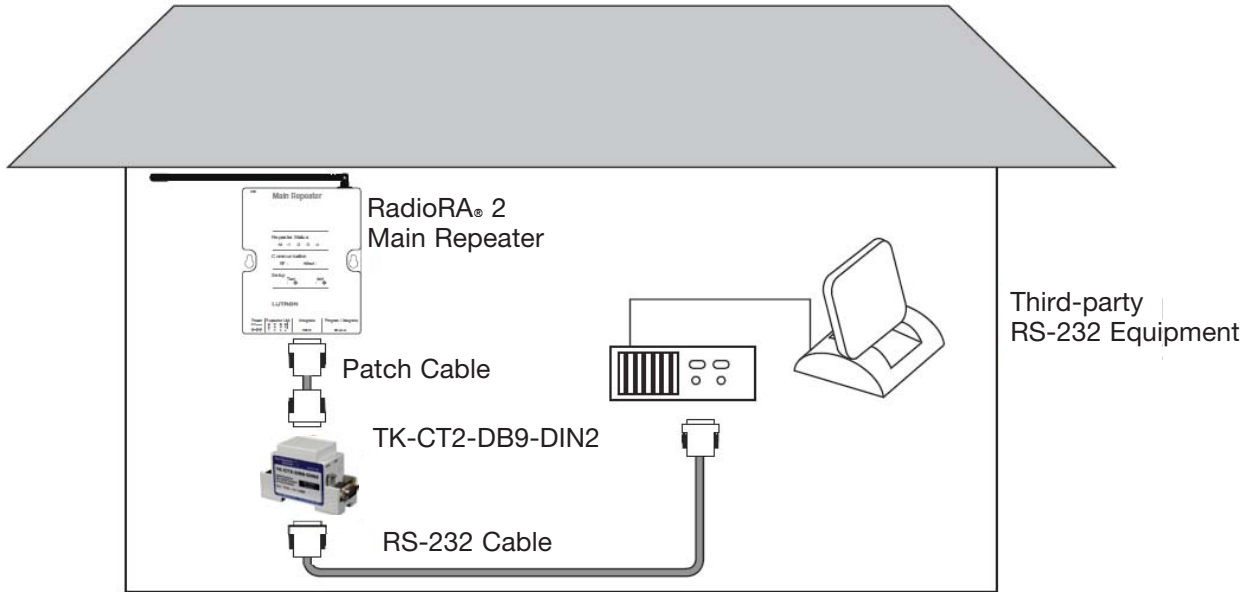

RS-232 Component Wiring Detail – Using Total Protection Solutions

Total Protection Solutions Model # TK-CT2-DB9-DIN2 with third-party RS-232 equipment

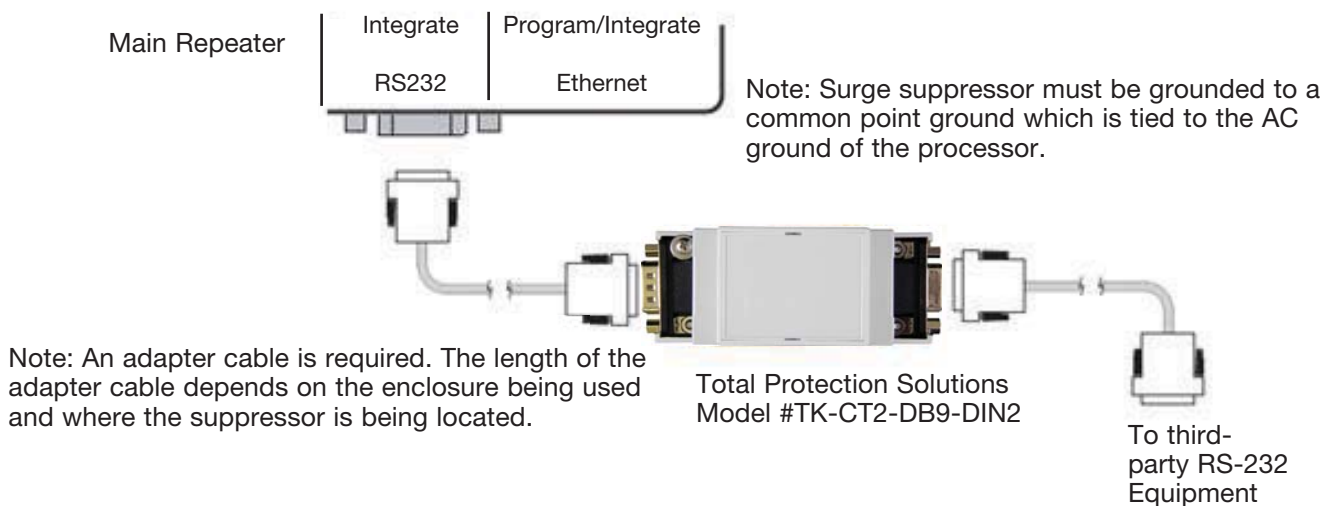

RadioRA® 2 (continued)

RS-485 Equipment Placement – Using Total Protection Solutions

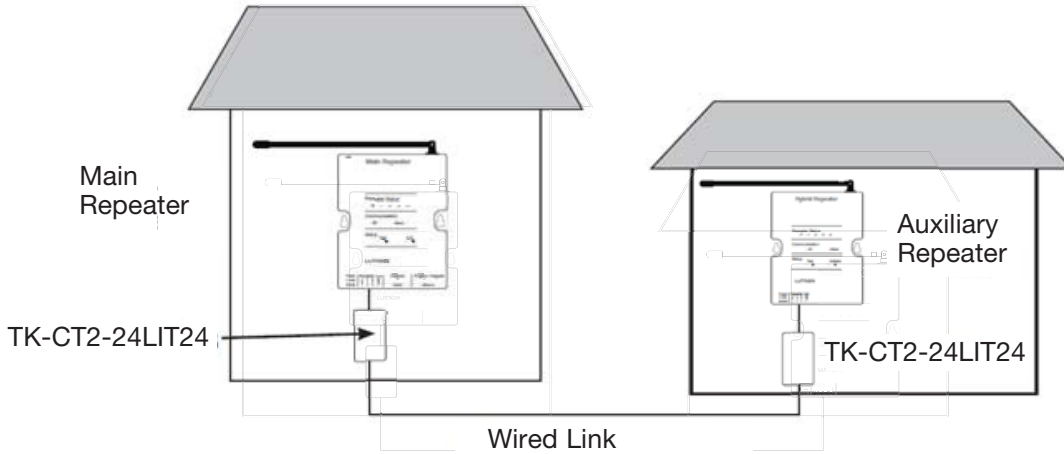

RS-485 Component Wiring Detail – Using Total Protection Solutions

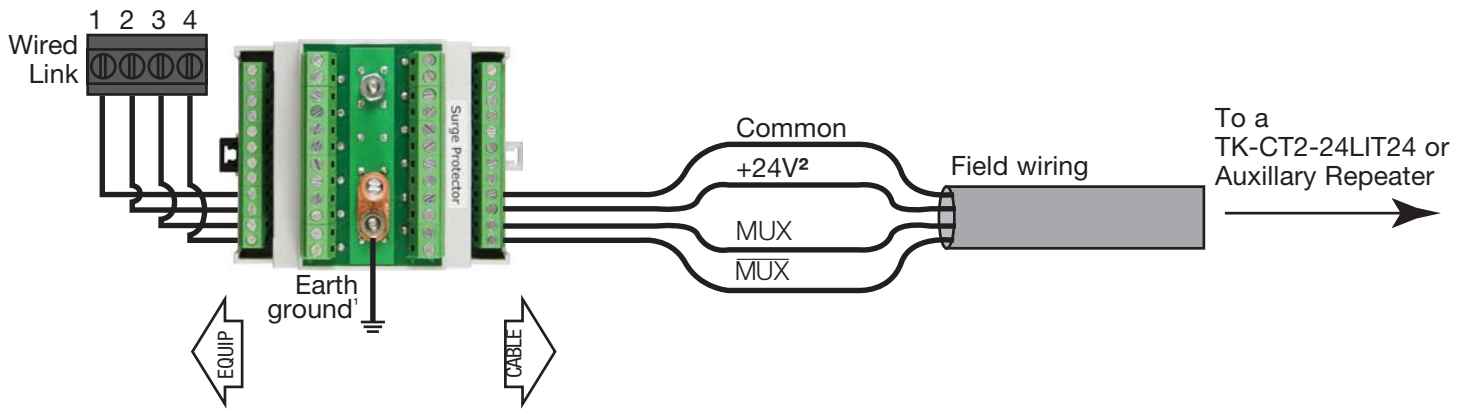

HomeWorks® QS (continued)

RS-485 Equipment Placement – Using Total Protection Solutions

Example: HomeWorks systems with low-voltage wire runs outside or between buildings using Total Protection Solutions

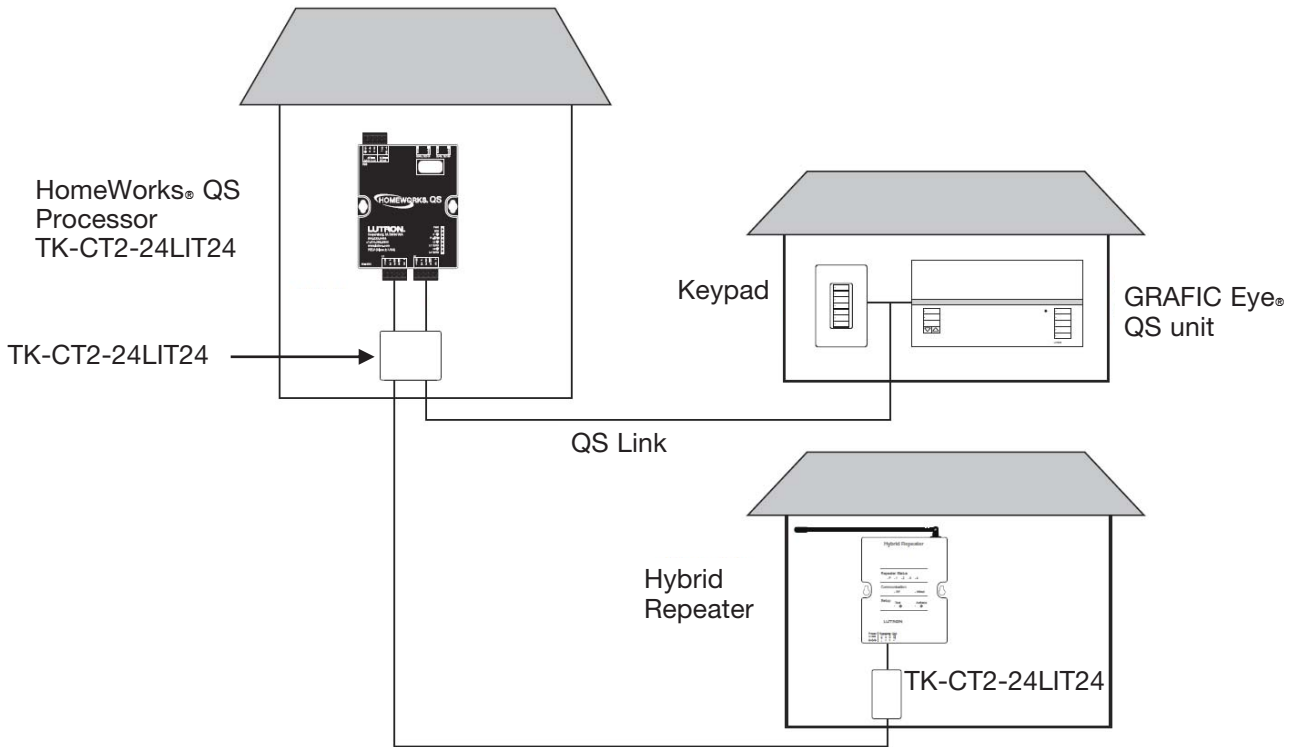

Example: System components that are wired greater than 500 ft (152.4 m) from the processor:

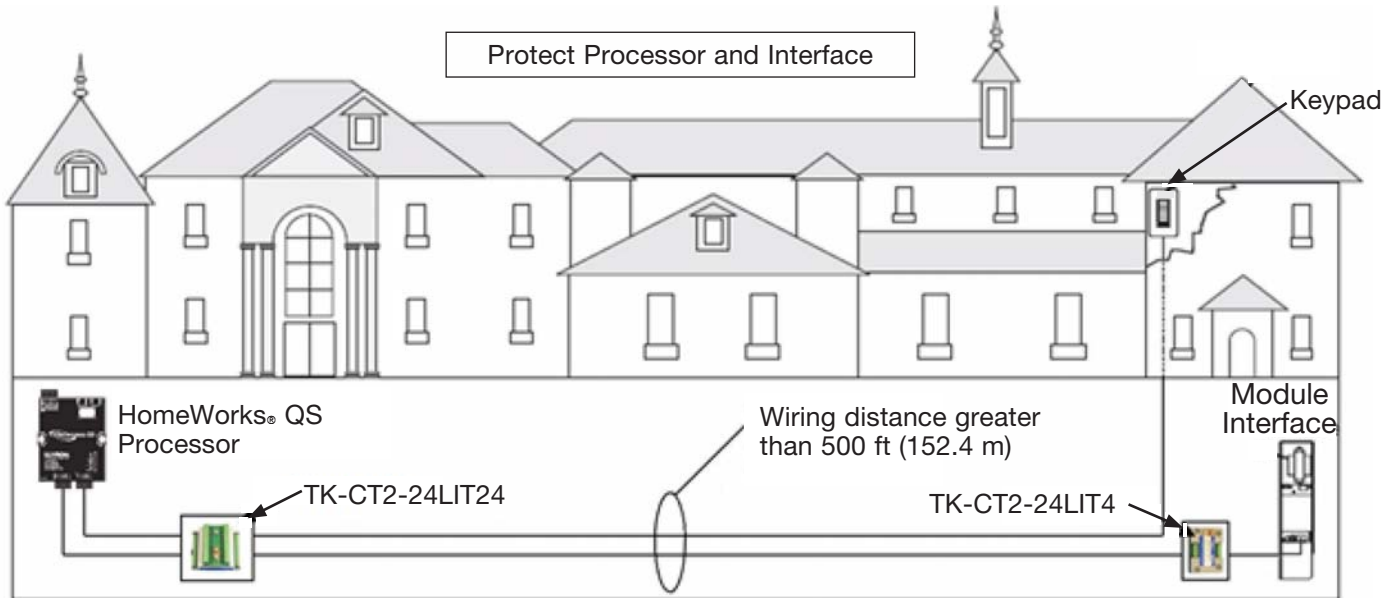

HomeWorks® QS (continued)

RS-485 Component Wiring Detail – Using Total Protection Solutions

Total Protection Solutions TK-CT2-24LIT24 with Inter-Processor Link, Module Interface Link, GRAFIK Eye® Link, Shade Interface or Dimmer Interface not powered by Processor

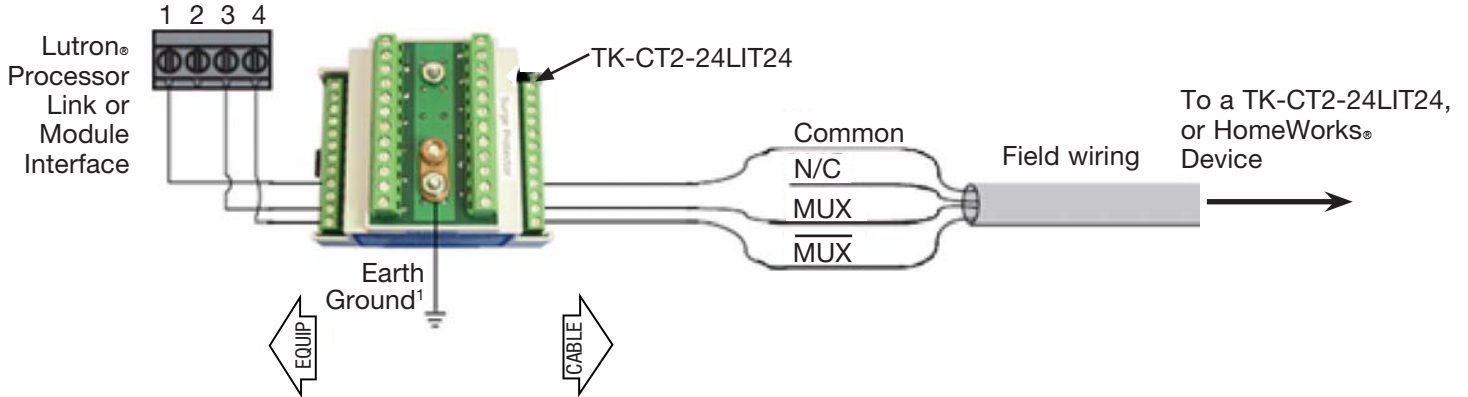

Total Protection Solutions TK-CT2-24LIT24 with Keypad Link, Hybrid Repeater Link

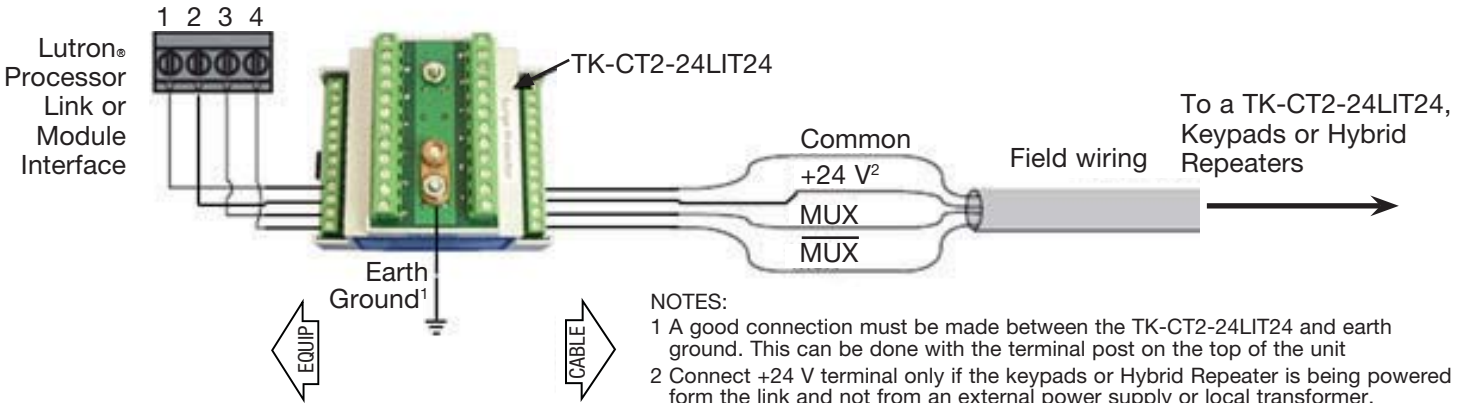

NOTES:

- 1 A good connection must be made between the TK-CT2-24LIT24 and earth ground. This can be done with the terminal post on the top of the unit
- 2 Connect +24 V terminal only if the keypads or Hybrid Repeater is being powered from the link and not from an external power supply or local transformer.
- 3 The TK-CT2-24LIT24, TK-CT2-24LIT12 and the TK-CT2-24LIT4 can be used on both dimming busses and RS-485 links.

HomeWorks® (continued)

RS-232 Equipment Placement – Using Total Protection Solutions

Example: Connection to third-party RS-232 equipment using Total Protection Solutions Model TK-CT2-DB9-DIN2

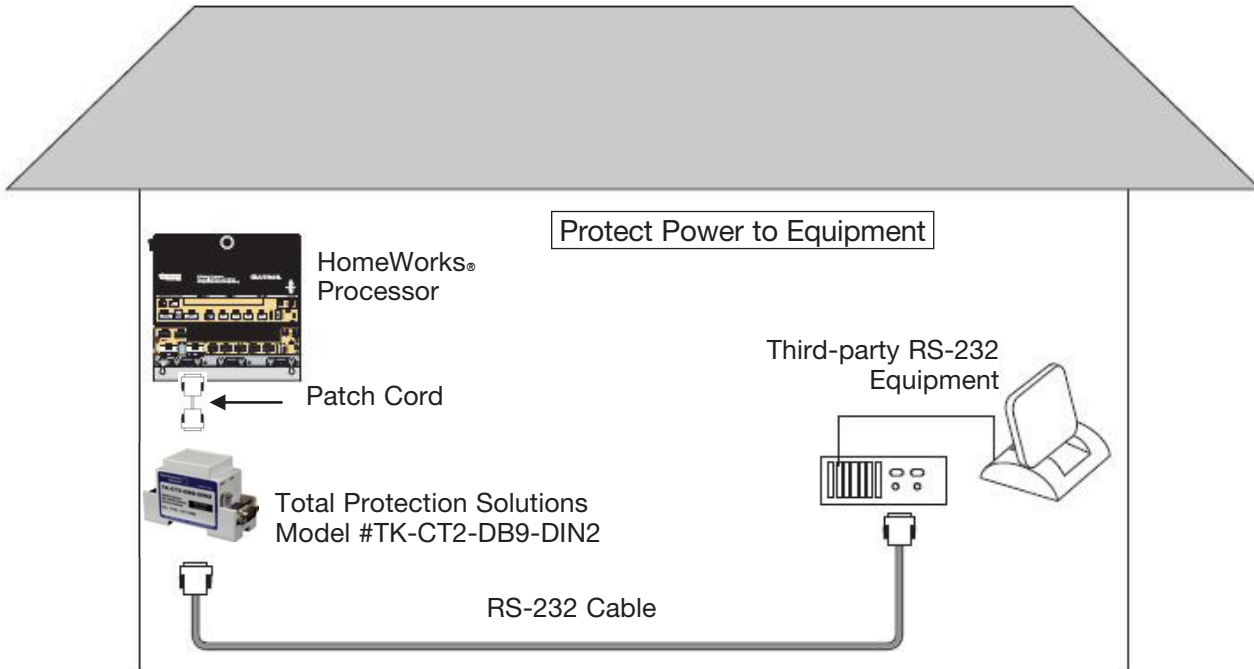

RS-232 Component Wiring Detail – Using Total Protection Solutions

Total Protection Solutions Model TK-CT2-DB9-DIN2 with third-party RS-232 equipment

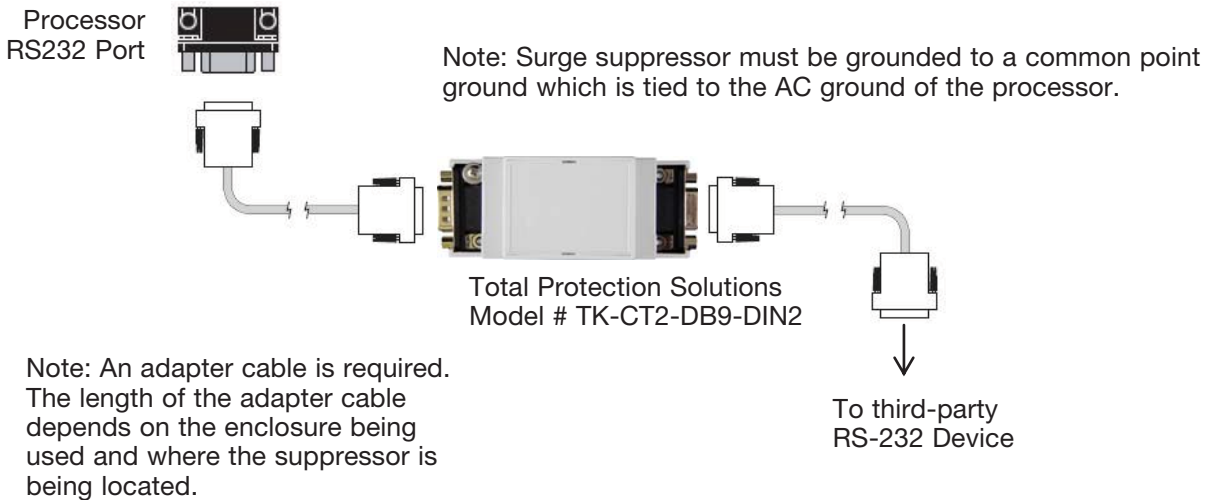

HomeWorks® (continued)

RS-485 Equipment Placement – Using Total Protection Solutions

Example: System components that are wired greater than 500 ft (152.4 m) from the processor:

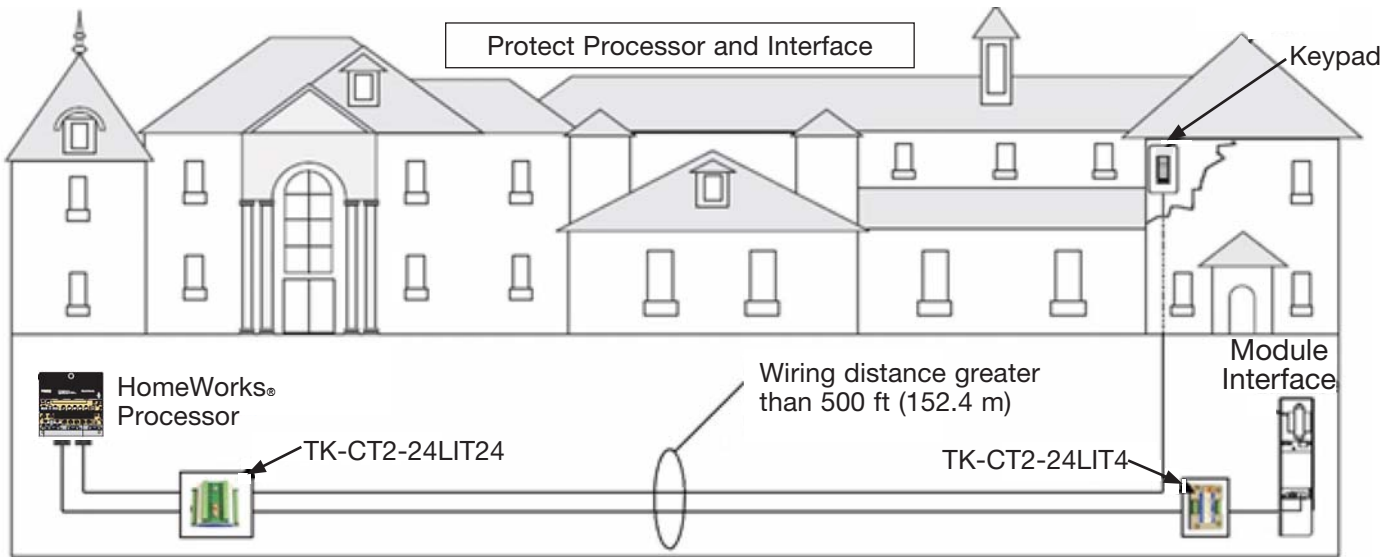

RS-485 Component Wiring Detail – Using Total Protection Solutions

Total Protection Solutions Model TK-CT2-24LIT24 with Inter-Processor Link, Module Interface Link, GRAFIK Eye® Link, Shade Interface, Dimmer Interface not powered by processor

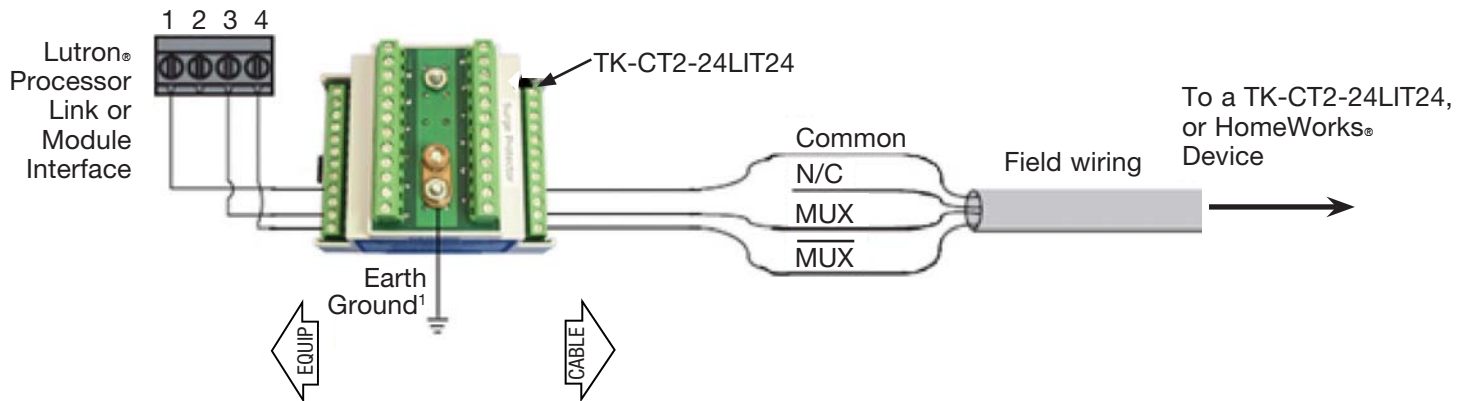

Total Protection Solutions Model TK-CT2-24LIT24 with Keypad Link, Hybrid Repeater Link

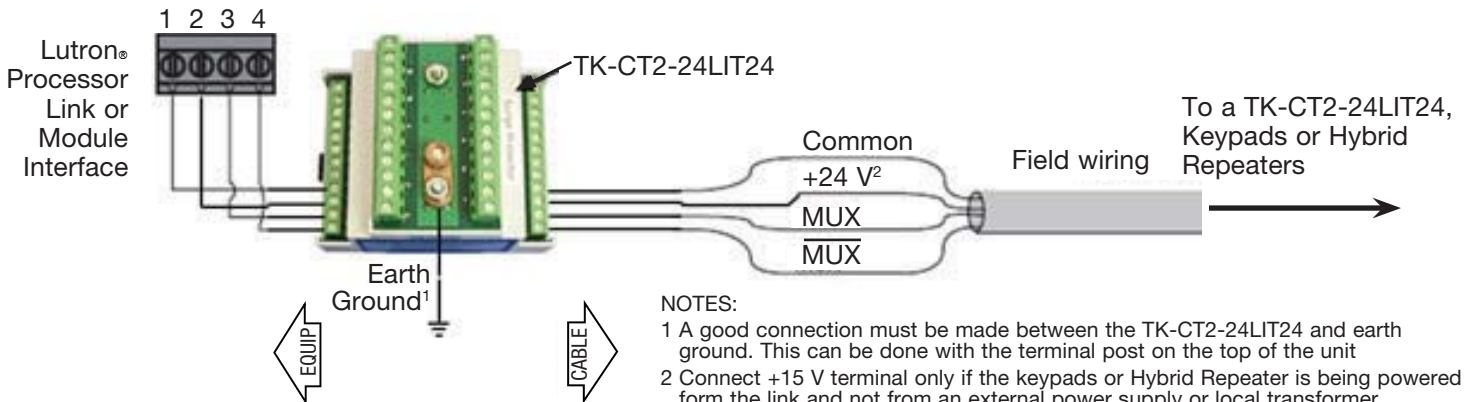

NOTES:

- 1 A good connection must be made between the TK-CT2-24LIT24 and earth ground. This can be done with the terminal post on the top of the unit
- 2 Connect +15 V terminal only if the keypads or Hybrid Repeater is being powered for the link and not from an external power supply or local transformer.
- 3 The TK-CT2-24LIT24, TK-CT2-24LIT12 and the TK-CT2-24LIT4 can be used on both dimming busses and RS-485 links.

HomeWorks® (continued)

H48/D48 Equipment Placement – Using Total Protection Solutions

Example: HomeWorks systems with low-voltage wire runs outside or between buildings using Total Protection Solutions

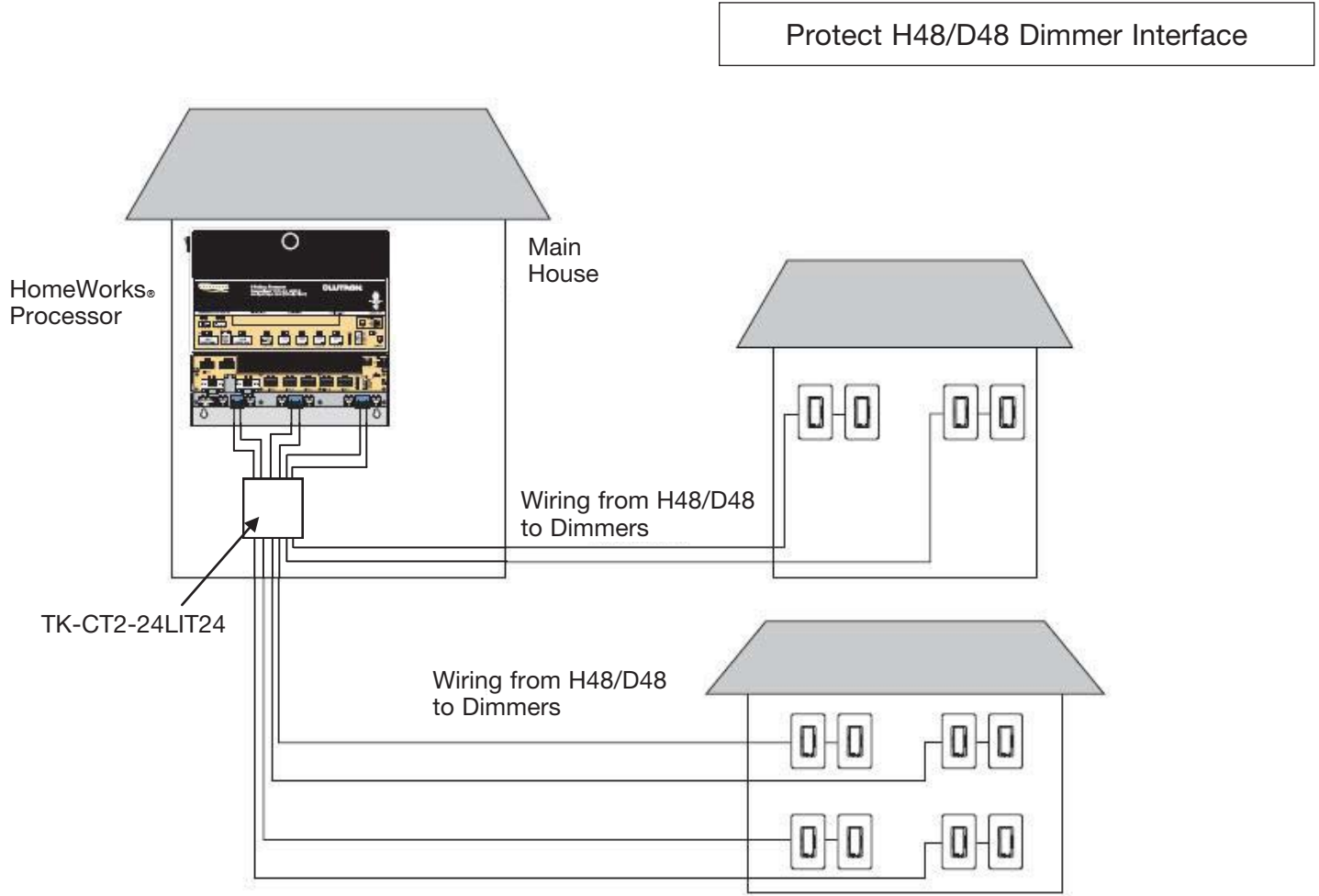

HomeWorks® (continued)

H48/D48 Component Wiring Detail – Using Total Protection Solutions

Total Protection Solutions Model TK-CT2-24LIT12 with H48 Dimmer Busses

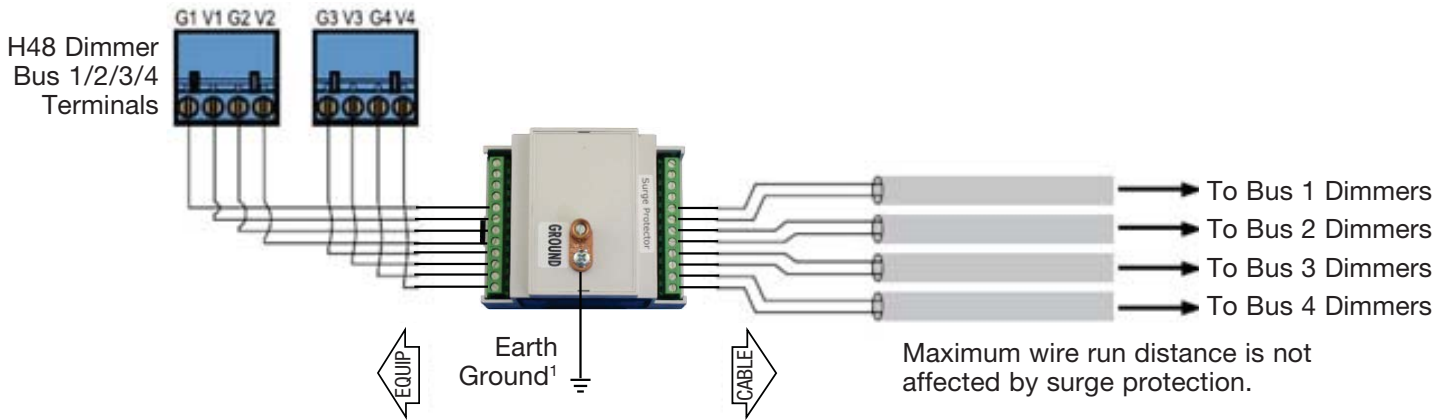

Total Protection Solutions Model TK-CT2-24LIT12 with Keypad Link, Hybrid Repeater Link

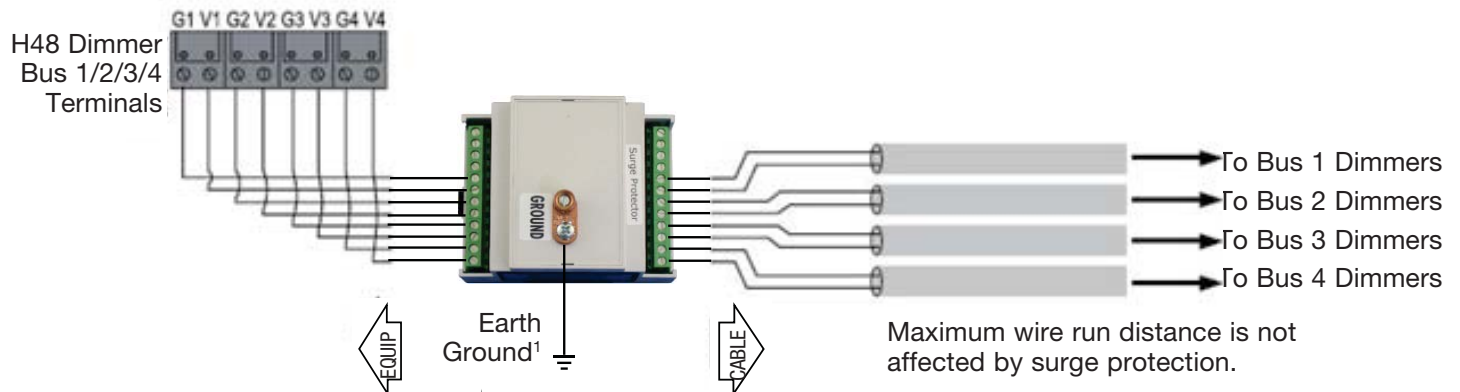

Notes:

- ¹ A good connection must be made between the TK-CT2-24LIT12 and earth ground. This can be done with the terminal post on the top of the unit.
- ² To protect an entire H48 Interface use (1) TK-CT2-24LIT12 or use (1) TK-CT2-24LIT24 for both dimming busses and RS-485 links.
- ³ To protect an entire D48 Interface use (1) TK-CT2-24LIT24 or use (2) TK-CT2-24LIT12.
- ⁴ The TK-CT2-24LIT24, TK-CT2-24LIT12 and the TK-CT2-24LIT4 can be used on both dimming busses and RS-485 links.

Combination RS-485 and H48/D48 Component Wiring Detail

Total Protection Solutions Model TK-CT2-24LIT24 with Inter-Processor Link, Module Interface Link, GRAFIK Eye® Link, Shade Interface, Dimmer Interface, Keypad Link & Hybrid Repeater Link



Note: The TK-CT2-24LIT24, TK-CT2-24LIT12 and the TK-CT2-24LIT4 can be used on both dimming busses and RS-485 links.

Lightning Strike Information

Lightning Protection Resources:

National Lightning Safety Institute: www.lightningsafety.com | Lightning Protection Institute: www.lightning.org

Global lightning distribution map

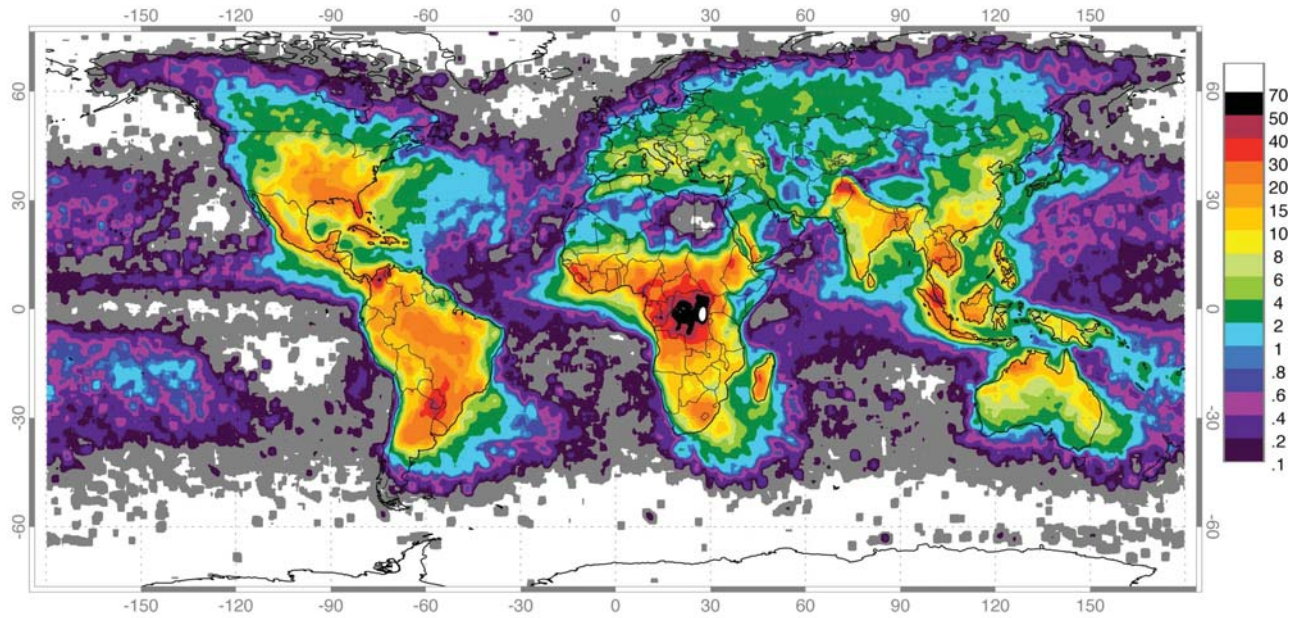

Low Resolution Full Climatology Annual Flash Rate

Global distribution of lightning April 1995-February 2003 from the combined observations of the NASA OTD (4/95-3/00) and LIS (1/98-2/03) instruments.

U.S. lightning distribution map

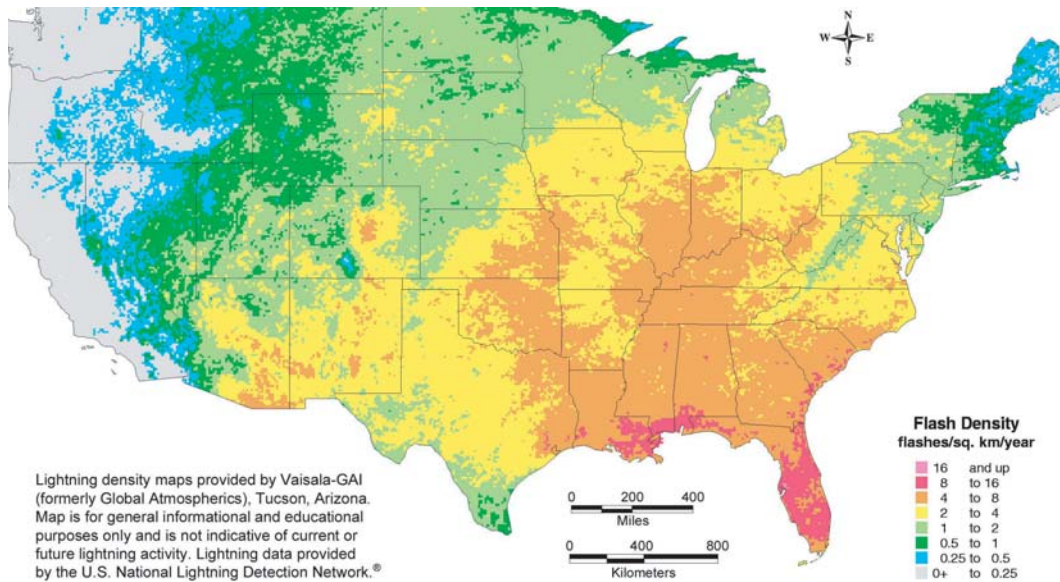

Lightning density maps provided by Vaisala-GAI (formerly Global Atmospheric), Tucson, Arizona. Map is for general informational and educational purposes only and is not indicative of current or future lightning activity. Lightning data provided by the U.S. National Lightning Detection Network.®

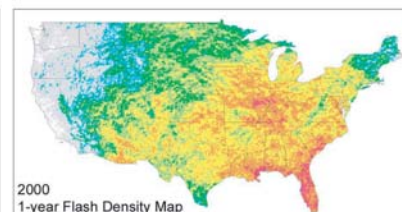
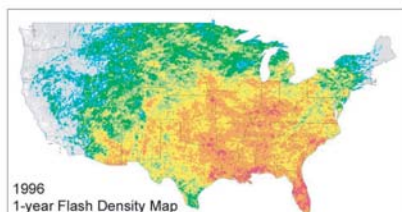

The 5-year Flash Density Map shows the average amount of lightning recorded in 1996-2000. The average amount of lightning that occurs in any given area varies significantly from year to year, as shown in the annual maps for 1996 and 2000.

Contact Information

Total Protection Solutions, LLC

PO Box 3760
 Winter Park, FL 32790-3760
 Phone: +1.800.448.4087
 Fax: +1.407.951.5887
 Web: www.TPSsurge.com
 Sales Email: Maureen@TPSsurge.com
 Technical Support: Bob@TPSsurge.com

Parts List

Total Protection Solutions, LLC Parts List

Breaker Panel Protection

TK-TTLP-1S240-FL Unlimited Amperage

Dimming Module Protection

TK-LT120-20A-DIN2 Max 20 A Circuit

TK-LT120-15A-DIN2 Max 15 A Circuit

RS232 Protection

TK-CT2-DB9-DIN2 RS232 DB9 Connection

RS-485 & H48/D48 Dimmer Interface Protection

TK-CT2-24LIT24 24 Wire (12 pair)

TK-CT2-24LIT12 12 Wire (6 pair)

TK-CT2-24LIT4 4 Wire (2 pair)

Lutron, HomeWorks QS, HomeWorks, RadioRA are registered trademarks and RadioRA 2 is a trademark of Lutron Electronics Co., Inc.

Lutron Contact Numbers

WORLD HEADQUARTERS USA

Lutron Electronics Co., Inc.
 7200 Suter Road
 Coopersburg, PA 18036-1299
 TEL: +1.610.282.3800
 FAX: +1.610.282.1243
 Toll-Free: 1.888.LUTRON1
 Technical Support: 1.800.523.9466
intsales@lutron.com

North & South America Technical Hotlines

USA, Canada, Caribbean:
 1.800.523.9466
Mexico:
 +1.888.235.2910
Central/South America:
 +1.610.282.6701

EUROPEAN HEADQUARTERS United Kingdom

Lutron EA Ltd.
 6 Sovereign Close
 London, E1W 3JF United Kingdom
 TEL: +44.(0)20.7702.0657
 FAX: +44.(0)20.7480.6899
 FREEPHONE (UK): 0800.282.107
 Technical Support: +44.
 (0)20.7680.4481
lutronlondon@lutron.com

ASIAN HEADQUARTERS Singapore

Lutron GL Ltd.
 15 Hoe Chiang Road
 #07-03, Tower 15
 Singapore 089316
 TEL: +65.6220.4666
 FAX: +65.6220.4333
 Technical Support: 800.120.4491
lutronsea@lutron.com

Asia Technical Hotlines

Northern China: 10.800.712.1536
 Southern China: 10.800.120.1536
 Hong Kong: 800.901.849
 Indonesia: 001.803.011.3994
 Japan: +81.3.5575.8411
 Macau: 0800.401
 Taiwan: 00.801.137.737
 Thailand: 001.800.120.665853
 Other Countries: +65.6220.4666